

# GAUGEMASTER



## PRODIGY EXPRESS

### DCC01 USER MANUAL

Version 1.1 2011

## TABLE OF CONTENTS

### 1 Getting Started

Introduction

Specifications and Features

Quick Start

Connecting to Your Layout

Running a Loco

Controlling Accessory Functions

Recalling Locos

Saving Locos

Deleting Locos

Emergency Stopping

Speed Steps

Overload and Short Circuit

Programming Decoders

Programming Loco on the Program Track

Programming Locos on the Main Track

Reading Loco's Decoder Values on the Program Track

Configuration Variables – CVs

Most Commonly Used CVs

A Word About CV #29

Consisting

Advanced Consisting

Programming Advanced Consists

Running Advanced Consists

Clearing Advanced Consists

General Trouble Shooting

Checklist for General Problems

Special Trouble Shooting

Contact Details

## Getting Started

### Introduction

**Note** Although there are Quick-start instructions on the back of the Cab/ Handheld, please read these instructions thoroughly to better understand and enjoy your Prodigy Express DCC system.

### Specifications and Features

**Input:** 15-16 volts DC, 2 Amps. It comes with a universal switching power supply (good for USA and Europe)

**Output:** DCC signal with 14.5 VA, for HO and N scales

**Maximum Current:** 2 Amps

**Note** Although you can draw more than 2 amps for short periods of time, it is not recommended

**Maximum number of Cabs:** Use up to 20 Cabs

**Address Capability:** 2-digit (1-127) or 4-digit (1-9,999)

**Speed Steps:** 14/28/128

**Accessory Functions:** 16 (F0-F15)

**Advanced Consisting**

**Program Loco on Program Track**

**Program Loco on Main Track**

**Read Loco on Program Track**

### Quick Start

#### Connecting to Your Layout

1. Using a small flat-bladed screwdriver attach two wires from the Main Track layout to the terminals marked Main Track and two wires from the Program Track to the terminals marked Program Track.
2. Plug the power supply into the base unit.
3. Plug the AC line cord into a wall outlet.
4. Double check all wiring, the power light should be on and you are ready to run your **decoder equipped** locos.

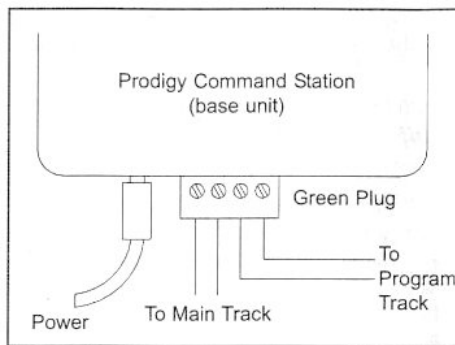

#### Running a Loco

To run a loco, you have to first know its address. Most decoders you purchase have the factory default address #3. Read your decoder and/or loco manual for your decoder address.

To select a loco, press the **LOCO** key. Using the numeric keypad (**0 - 9**), enter the loco address. Press **ENTER**. You have just acquired the loco.

The Cab will automatically remember the loco address for later recall.

Use the **DIRECTION** key to set the loco's direction. Turn the **THROTTLE** knob slowly to increase the loco's speed. The selected loco, or current loco, will begin moving. You can also tap the **+1** or **-1** to adjust the loco's speed. **Do not** hold the **-1** key, since this is also the **DEL** key and will delete the loco. To toggle the headlight (F0) on or off, press **0**.

#### Controlling Accessory Functions

To control accessory functions F1 - F9, press **1 - 9**. To control F10 - F15, press **SHIFT**, then **input the two digit function number**. Only functions up to F12 will show in the display, F13 to F15 will be activated but will not be displayed on the screen.

### Recalling Locos

To call up previous locos stored in the memory, press **RECALL**. You can recall up to 25 locos.

### Saving Locos

Recall back the five locos you wish to use in your next session, making sure all functions are off and the throttle is set to zero. To save the last five locos unplug the hand unit before turning off the power, SVdA will be displayed briefly confirming the save. After you have reset your five locos you can shut down the power to your DCC system and layout.

**Tip** Use the **DELETE** button to remove any unused locos from the stack before saving your favorite five.

**Note** Although the Cab can recall up to 25 locos for operation, if you "power off" the Cab from the base unit, it will only retain the last five locos previously saved.

### Deleting Locos

The Cab can store up to 25 locos. If you select a new loco when the Cab is full, the new loco will replace the current loco. The current loco will be lost. To prevent this, we recommend you recall unused locos and delete them by pressing and holding **DEL** for 2 seconds.

### Emergency Stopping

For emergency stopping of the current loco, press **STOP**. Pressing and holding **STOP** for 2 seconds will stop the Main Track output. The 2 lights on the base unit will blink. To restore the Main Track output, press and hold **STOP** for 2 seconds again.

### Speed Steps

Speed steps are incremental steps the loco takes to go from 0 to top speed. There are three speed steps: 14, 28 and 128. The higher the speed steps setting, the higher the number of different speeds on which the loco can operate. When you enter a new loco address (an address that has not been stored in the Cab's memory) Prodigy Express will set 28 speed steps as the default setting for that address. In order to operate your loco properly, you may need to change the speed steps setting to match the decoder's speed steps. To select other speed steps settings, press **SPD STEP** repeatedly until you see your desired speed steps setting. Then press **ENTER**. The selected speed steps setting will apply only to that address.

**Note** Use of the speed step button will not alter the speed step originally programmed into the decoder. It only matches the throttle to the decoder.

### Overload and Short Circuit

The base unit is rated at 2 amps. It is up to you to note how many locos and accessories can be run on the layout at the same time without triggering the circuit protector. If there is an overload or short circuit, the base unit will stop Main Track output for 2 seconds then resume. Please remove the overload or short circuit for proper operation. When operating larger layouts with numerous locos and accessories being operated at the same time you may need a DCC power booster.

Some common point wiring is shown below.

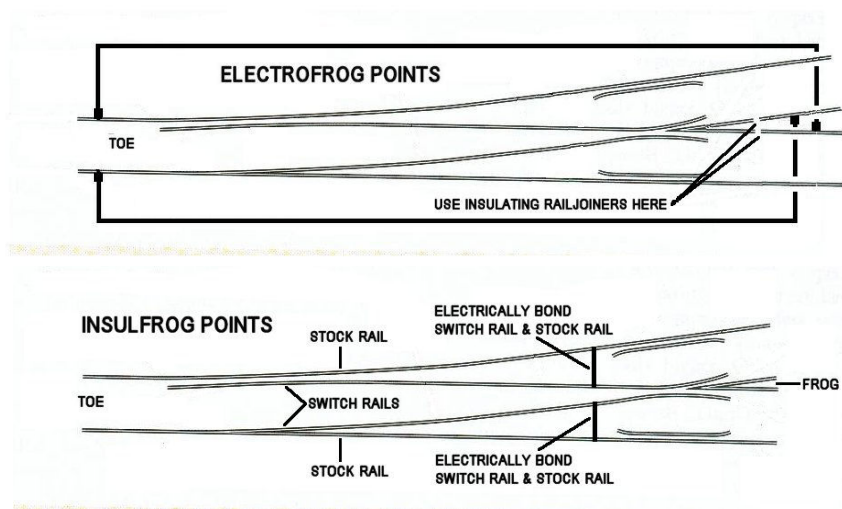

## Programming Decoders

The Prodigy Express allows you to easily program most NMRA compatible decoders. It guides you step by step through the programming process. No hexadecimal numbers are needed, to program decoders with this system. The Prodigy Express allows you to program decoders on a separate Program Track or on the Main Track layout, all without affecting any other locos operating on the Main Track.

### Decoder Terminology

**Note: Before you start programming, please familiarize yourself with the following terminology.**

**Loco Address:** The address is the number assigned to a decoder to identify the decoder.

**Start Voltage:** This is the voltage required to start the loco's motor and overcome its weight and friction to make it begin to move. You can program your loco with a start voltage so that it will begin to move as soon as the throttle is turned.

**Top Voltage:** The top voltage (top speed) is the voltage (speed) at full throttle.

**Acceleration Rate:** This rate simulates the drag of a heavy load as the loco speeds up so when you increase the speed setting, the loco will gradually increase its speed.

**Deceleration Rate:** This rate simulates the drag of a heavy load as the loco slows down so when you decrease the speed setting, the loco will gradually decrease its speed.

### Programming Loco on the Program Track

1. Place the loco on the Program Track. Press **PROG** to select "Prog Prog Track". Press **ENTER**.

2. First, "Adr" will flash, prompting you to program the loco address. Using **0 - 9**, enter the loco address followed by **ENTER**, or press **ENTER** to skip.

**Note: For the beginner or if you want to only program the loco address, you can stop right here.**

Put the loco back on the Main Track. Select the loco by pressing **LOCO** then enter the loco address and press **ENTER**. Now you can run the loco.

3. Next, "SV" will flash, prompting you to program the Start Voltage. Input data and then press **ENTER**.

4. Next, "Acc" will flash, prompting you to program the acceleration rate. Input data and then press **ENTER**.

5. Next, "dEc" will flash, prompting you to program the deceleration rate. Input data and then press **ENTER**.

6. Next, "TV" will flash, prompting you to program the Top Voltage. Input data then press **ENTER**.

7. Finally, "CV#" will flash, prompting you to program a CV (Configuration Variable).

At this point, you have already finished most of the decoder programming.

You can stop programming here by pressing **ENTER**.

8. If you want to program a CV, enter a CV number. Press **ENTER**. Then enter CV data. Press **ENTER**. "CV#" will flash again, prompting you to program another CV. To skip, press **ENTER**.

**Note** Programming a CV with incorrect data can cause a decoder malfunction.

Read your decoder manual carefully before programming a CV

### Programming Locos on the Main Track

Programming on the Main Track can save you the effort of moving a loco to the Program Track for programming. However, you have to know the loco address in order to program on the Main Track. Otherwise you have to program the loco on the Program Track. Not all decoders support the Program on Main feature. Please read your decoder's manual to check whether the decoder supports this feature.

1. To program on the Main Track, press **PROG** to select "Prog Main Track".

Press **ENTER**. The current loco address will flash, prompting you to program the current loco.

2. To program the current loco, press **ENTER**; to program another loco, enter its address and press **ENTER**.

3. The rest of the programming procedures are the same as the Programming on Program Track procedures (see above). We recommend you bring the loco to a stop before programming because if the moving loco has a bad pickup, it may fail to receive the program command, causing a malfunction.

### Reading Loco's Decoder Values on the Program Track

The Prodigy Express DCC system gives you the ability to read back CV values of a decoder equipped loco on the Program Track. This feature is useful if you do not remember the decoder address or what CV values your decoder has. Not all decoders support this feature. Please read your decoder's manual to check whether it supports this feature.

1. Place the loco on the Program Track.

2. Press **PROG** to select "rEAd Prog Track" then press **ENTER**.

3. First, "Adr" will flash, prompting you to read the loco address. Press **ENTER** to read, this might take several second. If the decoder does not support read back feature, you will receive an "Err" (Error message).

4. Next "CV#" will flash, prompting you to read a CV. To read a CV, enter a CV number and press **ENTER**. After reading a CV, press **ENTER**. "CV#" will flash again, prompting you to read another CV. To end the read process, press **ENTER**.

#### **More about Decoder Read Back**

Not all decoders support the read back feature. Although Prodigy Express has read back functions, it may still fail to read back the decoders. This does not mean that your Prodigy Express is defective. No DCC system in the world is able to read all decoders 100%. This will not affect the operation of the decoder because you are always able to program your decoder.

**NOTE:** The Prodigy Express will display the loco's active address which could be it's consist address if activated.

## **Configuration Variables – CVs**

Configuration Variables, also known as CVs, receive and hold entered data that allow the decoder to be tailored to a specific loco or accessory. Some CVs are also called registers. The Prodigy Express DCC system allows you to perform most basic programming without having to concern yourself with CVs or registers. Of course, if you want to program CVs to custom tailor your decoders or select certain functions, the Prodigy Express has this capability.

### **Most Commonly Used CVs**

The CVs listed on the chart are contained in almost all decoders, with additional CVs for extra functions – sound or light – in more specialized decoders. See the decoder manufacturer's instruction manual for a list of CVs contained in that specific decoder and what values to enter for those CVs.

### **A Word About CV #29**

CV29 is the most important CV of the decoder. Improperly programming the CV29 may cause decoder malfunction. We do not recommend you program CV29 yourself because the unit will take care of it for you in most cases. When you program your decoder's address with Prodigy Express, it will automatically program CV29. If you want to reverse the loco's polarity or set 14 speed steps, you have to reprogram CV29 after programming the loco's address. Please use the following table to reprogram CV29.

### **More About Programming Locomotive Address on the Program Track or Main Track**

To program a locomotive address involves programming a series of CVs such as CV1, CV17, CV18, CV19 and CV29. This can be somewhat complicated. For most decoders, Prodigy Express automatically handles this for you when programming the loco address. However, it may fail to program some old decoders and some new sound decoders made by QSI®. It does not mean that you cannot program these decoders. It only means you cannot use the Prodigy Express's easy address programming feature. For QSI® decoders please refer to your decoder's manual and use CV programming to program the loco address.

Prodigy Express' default setting CV29 = 2 CV29 = 34  
Change polarity only CV29 = 3 CV29 = 35  
Change to 14 speed steps only CV29 = 0 CV29 = 32  
Change polarity & 14 speed steps CV29 = 1 CV29 = 33

### **CV # Register # Function**

1 1 Short address  
2 2 Start voltage  
3 3 Acceleration rate (momentum)  
4 4 Deceleration rate (momentum)  
5 --- Top voltage  
6 --- Mid voltage  
7 --- Manufacturer version #  
8 --- Manufacturer ID #  
17 --- Extended address - upper & lower bytes, 4 digit addresses  
18 --- Extended address - upper & lower bytes, 4 digit addresses  
19 --- Advance consist  
29 5 Configuration data #1

For some old decoders, you have to skip the **Addr** programming and use the CV program mode to program CV29 with a value of 2 and CV1 with a short address (1-127). Detailed steps are as follows:

1. Press **Prog** to select **Prog Prog Track**
2. Press **Enter** six times until **CV#** displays on the screen
3. To select CV29, press 29 and **Enter**
4. **CV data** displays. Press 2 and **Enter**
5. **CV#** displays again. Select CV1 by pressing 1 then press **Enter**
6. **CV data** displays. Press the loco address (1-127) and then **Enter**

## Consisting

Sometimes more than one loco is needed to haul heavy loads. These grouped locos are known as a multiple unit or a consist. The Prodigy Express DCC system allows you to build consists quickly and easily.

### Advanced Consisting

You can only apply Advanced Consisting to a mobile decoder that has CV19 to support this feature. When you program a loco into an Advanced Consist, you actually program the consist number into the decoder's CV19, which will override the decoder's original address. Therefore, the loco will no longer respond to commands addressed to its original address, but rather only to commands addressed to the consist number. All decoders in the consist will receive the command addressed to the consist number at the same time and act as one until you clear the consist. The base unit does **not** hold the consist information. With Advanced Consists, **always** remember to clear the consist when you are finished or the locos will still run as part of the consist next time you use them.

### Programming Advanced Consists

1. Press **PROG** until "Cons SET" flashes in the LCD display. Then press **ENTER**.
2. "Cons #" will display, prompting you to enter a consist number. Enter a consist number, (a short address 1-127) followed by **ENTER**.

**Note** Write down the consist number. You will need it later to clear the Advanced Consist.

3. "Add Loco" will display, prompting you to add a loco into the consist group. Enter the address of a loco you want to add. Press **DIRECTION** if you want the loco's direction reversed (forward is the default setting). Then press **ENTER**.
4. "Add Loco" will display again, prompting you to add another loco into the consist group. You can add as many locos into your consist as you would like. To end programming, press **ENTER**.

### Running Advanced Consists

Running Advanced Consist is just like running a single loco.

After setting up your consist group, use the consist number to run the consist.

1. Press the **LOCO** key. Make sure "Loco" appears on the LCD. If not, press the **LOCO** key again. Enter the consist number and press **ENTER**.
2. Turn the throttle and all the locos in the consist will start moving together. To control an individual loco's accessory functions use either the consist number or the loco's original address. Read your decoder's manual to find how to control the accessory functions.

### Clearing Advanced Consists

1. Press **PROG** until "Cons cLr" flashes in the display. Then press **ENTER**.
2. "Cons#" will display, prompting you to input the consist number. Enter number of the consist you want to clear and press **ENTER**.

Once you clear the consist, each loco will respond immediately to its original speed command.

**Note** If you forget the consist number, each loco's address in the consist must be reprogrammed on the Program Track, or program CV19 to zero, in each loco.

**Many of our DCC manuals are available on-line in our Download section**

[www.gaugemaster.com](http://www.gaugemaster.com)

## General Trouble Shooting

It takes the Command Station, the decoders and your layout to make the DCC system work. This Trouble Shooting Section has been arranged in a manner easiest for you to find the cause of your problem. Please go through this section in the exact order it appears because each following set of instructions assumes that the preceding set has been tested and that component of the DCC system found not defective.

### **1. Plug in the power supply of the base unit. The pilot light should turn on.**

If not, make sure the power supply is securely plugged into the base unit and into a working AC wall outlet. Then unplug the power, wait 3 seconds and plug back in. If power light still does not turn on, send the unit in for repair.

### **2. Check the Main Track output.**

Place an analog loco or test light on the Main Track. The loco should buzz or the test light should light. If not, check all connections and make sure the rear green plug is securely plugged in. Make sure the screws on the green plug are tightened on the wire and not on the wire cover (insulator). If the analog loco still does not buzz or the test light does not light, send the unit in for repair. It is better to use a V.O.M (multi-meter) on the A.C. scale to check for track power, as DCC track power is A.C., not D.C.

### **3. Check the communication between the base unit and the Cab.**

Press key 2. F2 should momentarily display on the LCD and the Link light should blink. If there is still no communication, send the unit in for repair.

### **4. Your loco may have a pickup problem.**

You should periodically clean your track and your loco's wheels. Oxide coating or dirt on either the track or loco's wheels often causes intermittent and jerky operation.

**If you pass the above steps, you're Command Station and Cabs are fine. The problem may lie in the decoder.**

### **5. Your decoder may have lost its memory or is in Advanced Consist mode (CV19 is not 0).**

Reprogram the loco address and try again.

### **6. Your decoder may have too much momentum.** Program the loco with zero acceleration and deceleration rates.

### **7. The current loco speed command may not match the decoder's speed steps.**

Reprogram your decoder's address. When you program the decoder with Prodigy Express it will automatically set the decoder's speed steps to 28/128. Select 28 or 128 speed steps on the base unit and then try to run the loco.

### **8. Check the decoder wiring and make sure everything is correctly installed.**

### **9. Remove the decoder and test it on a decoder tester to make sure the decoder is fine.**

### **10. If the decoder is fine, check the loco to make sure the loco is fine before installing the decoder.**

## Checklist for General Problems

1. Clean your layout and the loco's wheels.
2. Check the layout's wiring.
3. Reprogram loco address and other data.
4. Reset the base unit by unplugging power supply.
5. Check loco for proper decoder installation.
6. Check wiring from the base unit to your layout.
7. Check for short circuits and/or stray objects lying across track rails.
8. Make sure the Link light flashes when you press F2.



## **Special Trouble Shooting**

### **The loco's headlight turns itself off**

When you press **0** to turn on the loco's headlight, the base unit will send the command to the decoder to turn on the loco's headlight. The base unit will not continuously send the accessory command to the decoder like the speed command. When the loco hits a dirty track and loses its power, it will reset and lose the accessory command. You should clean the track and the loco's wheel to improve the loco's pickup.

### **During operation all locos stop responding**

Unplug the power supply, wait 3 seconds and turn the power back on. If all the locos start to run and the system shuts down again, you may have too many locos and accessories connected to track power. Remove some locos and try again.

### **Your loco doesn't work while other locos work**

The decoder may have lost its memory. Reprogram loco address.

### **Your Cab operates locos but cannot program on the Program Track**

If the Link light flashes when you enter a data and press **ENTER**, then test the Program Track output. To test, place an analog loco on the Program Track. During the programming process, the Link light should be on and the analog loco should buzz. If the Link light is on and the analog loco does not buzz, it is a defective Program Track output.

Your Prodigy Express system is designed as a quick and easy introduction into DCC, replacing the hand set with any of the Prodigy Advance controllers will expand the system with additional features. This will include accessory decoder and route operation – fast clock and old style consisting – extended READ and system options. PC interface and wireless control is also available with some products.

Your Prodigy Advance products carry a 1 YEAR GUARANTEE subject to the usual conditions  
Your statutory rights are not affected

If you believe your unit is faulty, please telephone us in the first instance. We will advise you of your best course of action. If it involves sending anything back, please send it to the address below via insured post and packed securely.

Gaugemaster Controls Ltd, Gaugemaster House, Ford Road, Arundel, West Sussex BN18 0BN  
Tel. No: 01903 884321 Fax. No: 01903 884377 Email: [gaugemaster@gaugemaster.co.uk](mailto:gaugemaster@gaugemaster.co.uk)

Web: [www.gaugemaster.com](http://www.gaugemaster.com)

Registered in England. Reg. No: 2714470



The LCD main display icons are used in all operation to display both numbers and symbols

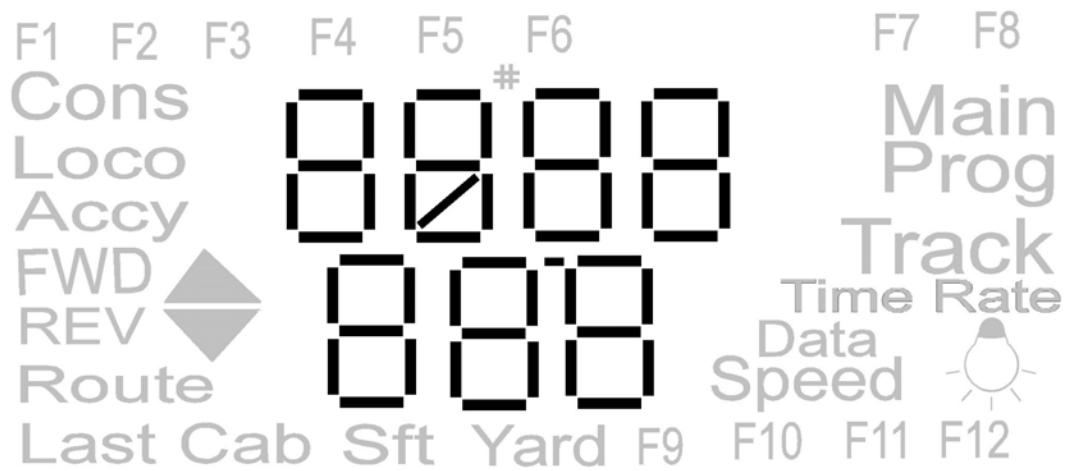

Function icons are displayed when operating loco functions

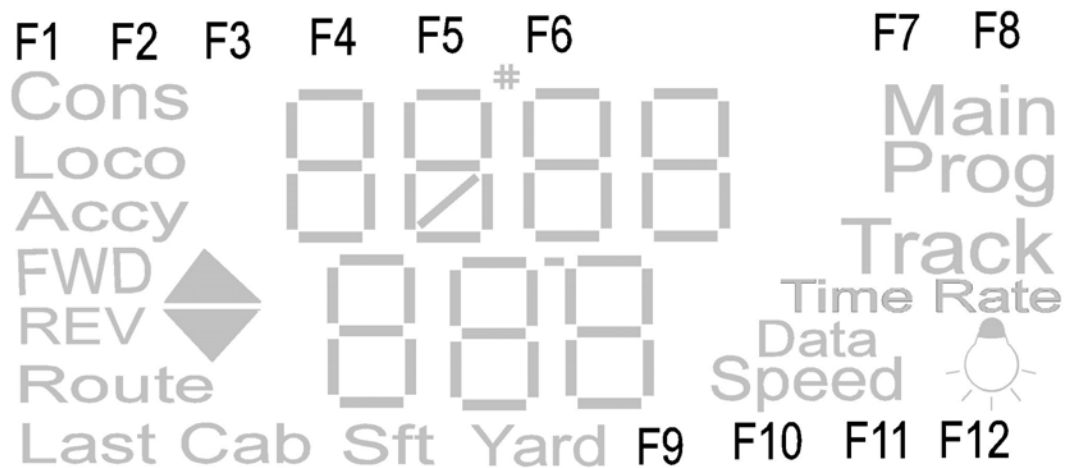

FWD / REV and SPEED icons display the loco speed and direction of travel  
The LAMP icon (F0) illuminates when the loco lights are activated

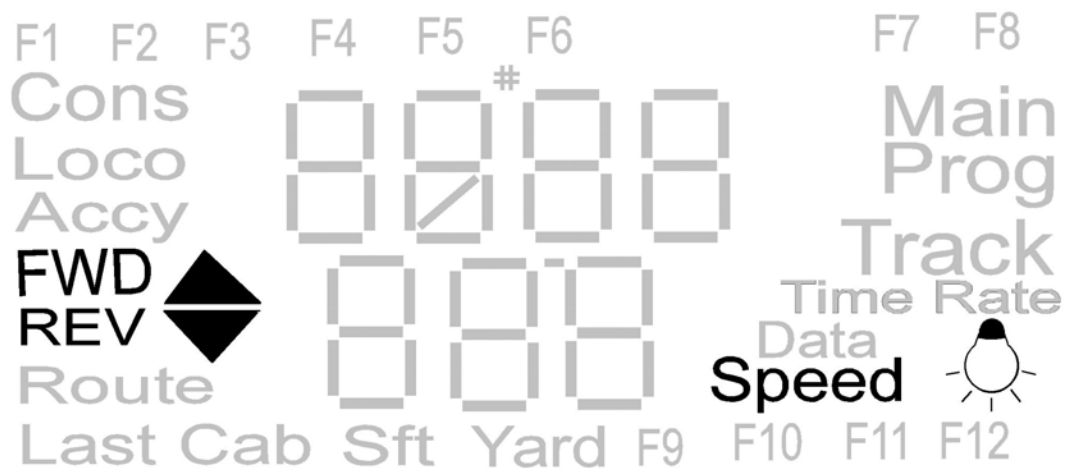

The MAIN / PROG / TRACK and DATA icons are displayed in programming and (READ) modes; the shift icon is not used on the Express hand set.

