

# Cobalt Classic $\Omega$ (omega)

## OWNERS MANUAL



CB Omega -A-0314

### Installing the Cobalt Classic $\Omega$ turnout motor

First, assemble your Cobalt Classic  $\Omega$  turnout motor: The throw arm is already pre-centred to make this easy for you.

- (1) Insert the fulcrum bar into the slides (The horizontal part of the bracket with the holes can be either at the top or bottom. We usually have it at the bottom).
- (2) Now add the throw wire, passing the straight end upwards through the centre hole of the adjustable fulcrum bar and then inserting the bent end of the wire into the smaller top hole on the end of the throw arm. Secure the throw wire in place with the washer head screw provided.
- (3) Add the pre-cut self adhesive foam pad to the top of your Cobalt Classic  $\Omega$  motor (leave the protective top on the pad until installation)

#### Now we are ready for the installation.

As well as the pre-cut foam pad, we include mounting screws with every Cobalt Classic  $\Omega$  turnout motor so all you will need are basic tools.

You will need a screwdriver and a drill, plus both 1.5mm (for screw pilot holes) and 10mm drills for the throw-wire installation. (The exact drill sizing you use is not critical so close or imperial sized drills will be OK). If the baseboard is over 20mm/0.75" thick, increase the larger drill size.

- (1) Mark the position of the hole in the turnout tie-bar with the turnout blades held at their mid-way position. This hole may be at the centre or at the end of the tie-bar.
- (2) Make a pilot hole at that mark, then drill right through the baseboard using the larger drill bit. Be sure to keep the drill vertical as you drill. (It is also good practice to use a countersink bit to clean up the hole top and bottom a little after drilling)
- (3) Remove the top protective layer from the self adhesive pad and from below the baseboard, insert the throw wire into the hole in the tie bar. When you are sure that your Cobalt Classic  $\Omega$  is centralised relative to the hole, and aligned properly along the turnouts axis, press it into position on your baseboard. (it can face either way). Test operation.
- (4) Adjust the fulcrum bar as needed by raising or lowering it. Lowering it increases throw & blade pressure. Raising it reduces throw & pressure.
- (5) When happy with operation, add a small drop of PVA to the case where it meets the fulcrum bar to hold it in position.
- (6) Use screws provided to screw Cobalt Classic  $\Omega$  permanently in position.

### Owners Manual

## Cobalt Classic $\Omega$

The DCCconcepts Cobalt Classic  $\Omega$  (Omega) is the most powerful and most reliable turnout motor in its class and it is able to be used with all scales, from the diminutive T scale, through to Z, N, TT, HO, OO, EM, P4, S, O & G.

Cobalt Classic  $\Omega$  is easy to install, quiet and very reliable. It has three inbuilt SPDT switches - One is directly "Diode linked" to the drive power inputs for computer IO (feedback) or other low power applications. The other two SPDT switches are fully independent with higher power handling for frog power control or any other switching needs you may have. This makes DCCconcepts Cobalt the most versatile point motor available... and the answer to all layout wiring needs!

Cobalt Classic  $\Omega$  is powered by low voltage DC and it is changed by reversing the polarity of the DC power.

We recommend that you use a regulated DC power supply between 9 and 12v DC, however we do understand that some systems for larger scales have higher accessory voltage power supplies and that DCC accessory decoders may have higher output voltages, so we've added a simple "voltage range change" switch to the Cobalt Classic  $\Omega$ . This allows it to accept two power input ranges, 6~12v or 12~18v.

Please read all of this manual before you install your Cobalt Classic  $\Omega$ . It contains all the detailed information you'll need for installation and wiring. More manuals and "how to" videos that add even more detail will be available on our Website.

### Cobalt Classic $\Omega$ turnout motor Specifications

**Dimensions:** Body only: 28mm x 38mm x 52mm deep  
Top overall inc Fulcrum and tabs: 40mm x 45mm  
Depth inc soldering-free connectors: 68mm

**Power:** Switchable 6~12v or 12~18v DC. Avg power 20mA

**Connection:** 9 way spring terminals. Wire diameter up to 32x.2 or 18g. Ideal .16x.2 or 20g. Minimum 7x.2 or 24g

**Control:** Change turnout by reversing polarity of DC voltage. Use SPDT switch & DCCconcepts PSU-2, DC supply plus DPDT switches. DCCconcepts switch packs are economical and include both switches and a panel LED selection.

**DCC/Digital:** Use with DCCconcepts ADfx-2 or ADfx8 decoders, as these also have excellent added features and are excellent value. If using other brands pre-check they can deliver 20mA during the change cycle. (even though 20mA is very low current some cannot)

### Cobalt Classic $\Omega$ Life-time Warranty

DCCconcepts' guarantees and warranties are always made in respect of the original owner of the products. While our first priority is to always be sure that users of our products are given the best possible service we do also reserve the right to request proof of purchase so we can properly establish that you were the original purchaser and user of the product.

DCCconcepts use the best quality materials, thoroughly testing each and every Cobalt Classic  $\Omega$  motor multiple times prior to packaging them for sale and so we have no hesitation in providing you with the best warranty possible.

**Simple promises only need simple words:**

**If your Cobalt Classic  $\Omega$  ever fails or needs service when being used under fair and reasonable conditions we will repair/replace it at no charge. We offer this guarantee for as long as you own it.**

Cobalt turnout motors and the Cobalt accessory range are designed & manufactured by DCCconcepts Pty Ltd.  
Sales@DCCconcepts.com  
www.DCCconcepts.com



## Wiring your Cobalt Classic Ω turnout motor

**Important:** Cobalt Classic Ω has a different range of connections to the original "Cobalt Analog" motor

There are 9 spring terminals on Cobalt iP Ω. The terminals will accept a wide range of wire sizes. Use the heaviest convenient wire size. The wire should be stripped carefully exposing appx 10mm of bare wire. The best method is to "ring-strip" the insulation and then twist it as it is removed, This ensures that there are no free copper strands.

**Note:** The wire will always be more secure if it is NOT tinned

This drawing shows the label that is applied to each Cobalt Classic Ω turnout motor. Wiring information is also repeated on the bottom of the PCB to ensure it's never lost.

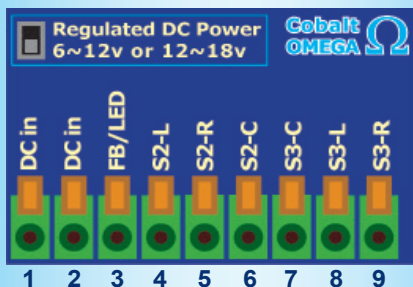

- 1,2 DC or decoder power input. Range 6~18v DC
- 3 Common for 1 & 2. For feedback, LEDs, other
- 4 Switch 2, Left terminal
- 5 Switch 2, Right terminal
- 6 Switch 2, Common Terminal
- 7 Switch 3, Common Terminal
- 8 Switch 2, Left terminal
- 9 Switch 2, Right terminal

**Note please:**  
Switch 1 is for low power use.  
Switch 2 and 3 are both high power / max 5A

## Basic wiring diagram for analog control using a more conventional single output regulated DC power supply

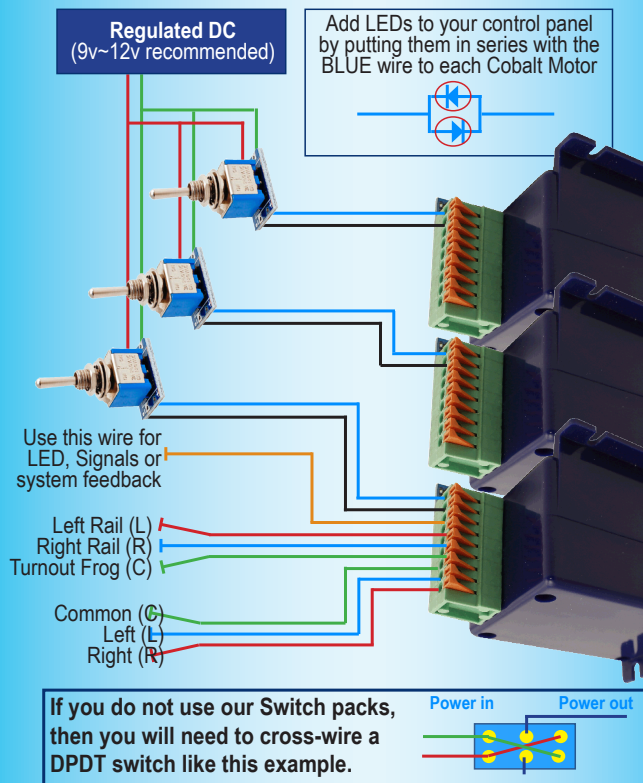

## Standard wiring diagram for DIGITAL control using the very versatile DCCconcepts AD2fx and AD8fx Decoders

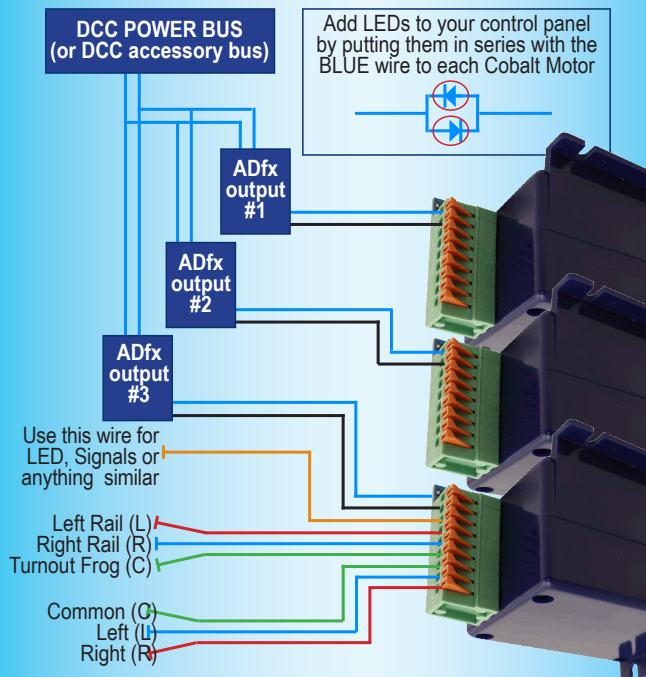

DCCconcepts AD2fx and AD8fx Decoders have enough power to change several Cobalt plus new features including optional 1 or 2 button control AND direct computer IO or feedback. They work well with DCC & DC too

## Advanced wiring diagram for analog control using the innovative DCCconcepts PSU-2 Split power supply

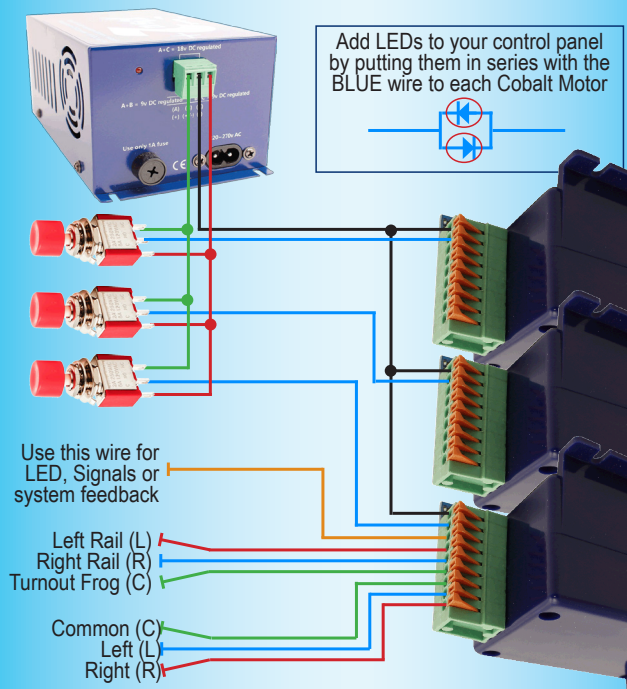

Cobalt Classic Ω has a "Voltage Range Switch" on the PCB, This gives a choice of 6~12 or 12~18v DC & all you need to do is change the switch so that it matches your Power supply voltage or Accessory decoder output.